

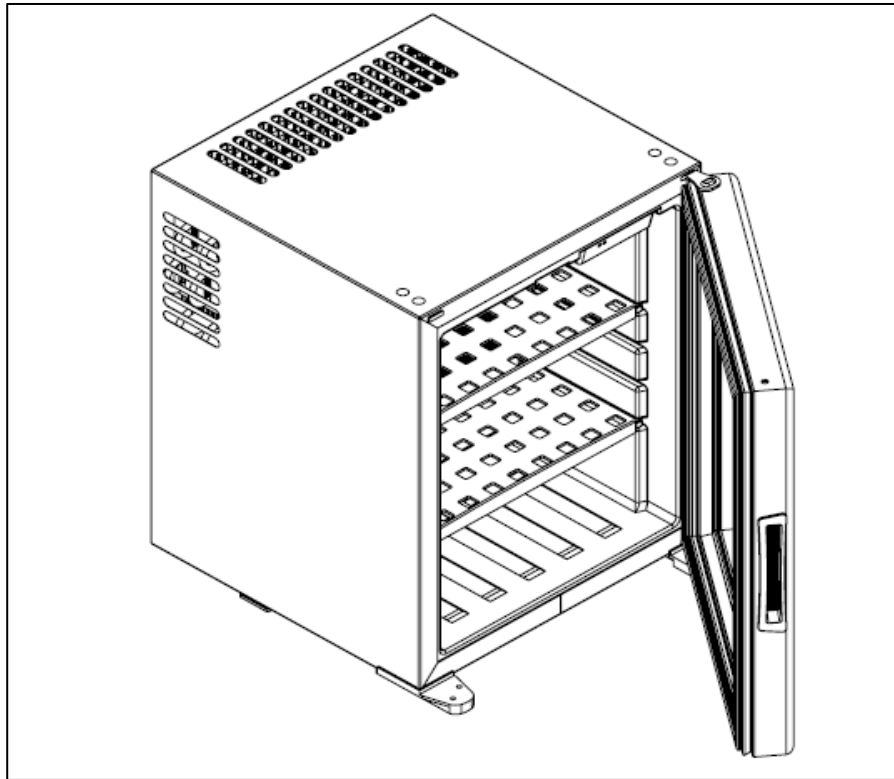

**Bädd & Bad AB**  
Grustagsgatan 22  
254 64 Helsingborg, Sweden  
Tel. +46 42 26 66 60

Revizyon no / Revision no : 03  
Revizyon tarihi / Revision date : 30.01.2024  
Model: SM 201-THG MINIBAR

## TECHNICAL SPECIFICATIONS



**MODEL: 81914456**

## TECHNICAL DATA SHEET

### CHARACTERISTICS

➤ Compartment Type	: Cellar/ Killer
➤ Energy Efficient Class	: G
➤ Climate Class	: N
➤ Energy Consump.	:175 kWh/a
➤ Energy Efficiency Index	:223 %
➤ Power	:50 W
➤ Voltage / Freq.	: 110 V - 240 V / 50-60 Hz.
➤ Defrosting Type	: Automatic
➤ Noise Emission	: 23 (dB(A) re 1 pW)

### ACCESSORIES

➤ Internal Light	: Standart
➤ Lockable Door	: Opsiyonel
➤ Door Hinge Side	: Right
➤ Reversible Door	: Yes
➤ Thermostat Control	: Electronic

### TECHNICAL SPECIFICATIONS

➤ External Dims.	: 435x360x387,5 mm (HxWxD)
➤ Internal Dims.	: 360x297x187 mm (HxWxD)
➤ Pack. Dims.	: 482x408x457 (HxWxD)
➤ Pack. Volume	: 0,09 m <sup>3</sup>
➤ Gross Volume	: 21,8 lt
➤ Total Volume	: 20 lt
➤ Gross Weight	: (11,8±1) kg
➤ Net Weight	: (10,8±1) kg
➤ Outer Body	: 0.4 mm.PVC Kaplı Sac / 0,4 PVC Cooted Sheet
➤ Inner Liner	: Hips
➤ Insulation Material	: Sert P.U. / Rigid P.U.
➤ Blowing Agent	: C.Pentane
➤ Insulation Density	: 38~40 kg/m <sup>3</sup>